



ALTV2432 Series CCTV Power Supplies

Installation Guide

Models Include:

- ***ALTV2432***
 - ***24VAC @ 8 amp (200VA)
or 28VAC @ 7 amp.***
 - ***Thirty-two (32) Fuse Protected Outputs.***
- ***ALTV2432CB***
 - ***24VAC @ 8 amp (200VA)
or 28VAC @ 7 amp.***
 - ***Thirty-two (32) PTC Protected Outputs.***
- ***ALTV2432350***
 - ***24VAC @ 14 amp (350VA)
or 28VAC @ 12.5 amp (350VA).***
 - ***Thirty-two (32) Fuse Protected Outputs.***
- ***ALTV2432350CB***
 - ***24VAC @ 14 amp (350VA)
or 28VAC @ 12.5 amp (350VA).***
 - ***Thirty-two (32) PTC Protected Outputs.***
- ***ALTV2432600***
 - ***24VAC @ 28 amp (700VA)
or 28VAC @ 25 amp (700VA).***
 - ***Thirty-two (32) Fuse Protected Outputs.***
- ***ALTV2432600CB***
 - ***24VAC @ 28 amp (700VA)
or 28VAC @ 25 amp (700VA).***
 - ***Thirty-two (32) PTC Protected Outputs.***

Overview:

These Altronix CCTV Power Supplies provide 24VAC/28VAC distributed via thirty-two (32) fuse or PTC protected outputs for powering CCTV Cameras, heaters and other video accessories.

Thirty-two (32) Output ALTV2432 Reference Chart:

Altronix Model Number	Output Voltage	Total Output Current (Power)	Number of Outputs	PTC Protected Outputs (Class 2 power limited)	Fuse Protected Outputs	Output Current (max per output)	115VAC 50/60Hz Input Current
ALTV2432	24VAC	8 amp	32	-	x	3.5 amp	2.9 amp
	28VAC	7 amp					
ALTV2432CB	24VAC	8 amp	32	x	-	2.5 amp	2.9 amp
	28VAC	7 amp					
ALTV2432350	24VAC	14 amp	32	-	x	3.5 amp	2.7 amp
	28VAC	12.5 amp					
ALTV2432350CB	24VAC	14 amp	32	x	-	2.5 amp	2.7 amp
	28VAC	12.5 amp					
ALTV2432600	24VAC	28 amp	32	-	x	3.5 amp	5.4 amp
	28VAC	25 amp					
ALTV2432600CB	24VAC	28 amp	32	x	-	2.5 amp	5.4 amp
	28VAC	25 amp					

Specifications:

- Surge suppression.
- AC power LED indicator.
- Power ON/OFF switch / circuit-breaker.
- Unit maintains camera synchronization.
- Ease of installation saves time & eliminates costly labor.
- Spare fuses included (on fuse protected models).

Enclosure Dimensions:

13"H x 13.5"W x 3.25"D

Installation Instructions:

1. Mount unit in desired location.
2. Turn OFF main switch on unit (Figs. 1-3, pgs. 4-6).
3. All units are factory set for 24VAC operation.
For 28VAC operation, adjust unit prior to mounting and applying power as follows: Change the wire position so that the black wire [28V] is connected to the terminal marked [P] and the yellow wire [24V] is connected to the terminal marked [S].
4. Connect AC power to the black and white flying leads of the transformer(s) (Figs. 1-3, pgs. 4-6), secure green lead to earth ground. Use 18 AWG or larger for all power connections.
5. Measure output voltage before connecting devices. This helps avoid potential damage.
CAUTION: Determine the maximum operating voltage of the equipment being powered before adjusting the output voltage.
6. Connect devices to terminals marked [1P - 1N through 16P - 16N] on PD16W/PD16WCB board (Figs. 1-3, pgs. 4-6), carefully observing polarity. Terminals marked [1P - 16P] are of the same polarity.

7. Turn main switch on unit to the ON (RESET) position (*Figs. 1-3, pgs. 4-6*).
8. Green LED(s) will illuminate when unit is powered.
9. Upon completion of wiring, secure enclosure door with screws (supplied).

**Caution: Equipment to be installed / serviced by authorized / trained personnel only.
Shut branch circuit power before installing / servicing equipment.**

WARNING: To reduce the risk of fire or electric shock, do not expose the unit to rain or moisture. This installation should be made by qualified service personnel and should conform to all local codes and in accordance with the National Electrical Code. Use 75 C or higher rated UL insulated wiring for connecting the unit to the mains.

Terminal Identification:

PD16W - Power Distribution Module

1P - 16P	AC output.
1N - 16N	AC output.

Fig. 1
ALTV2432 • ALTV2432CB

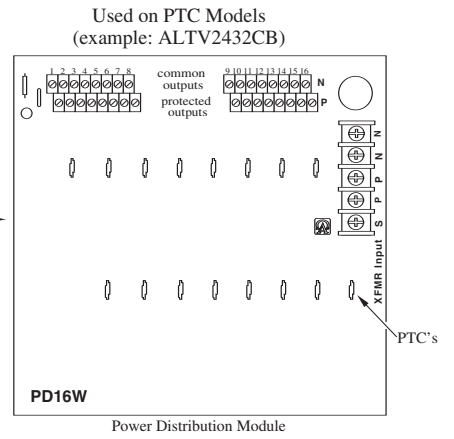
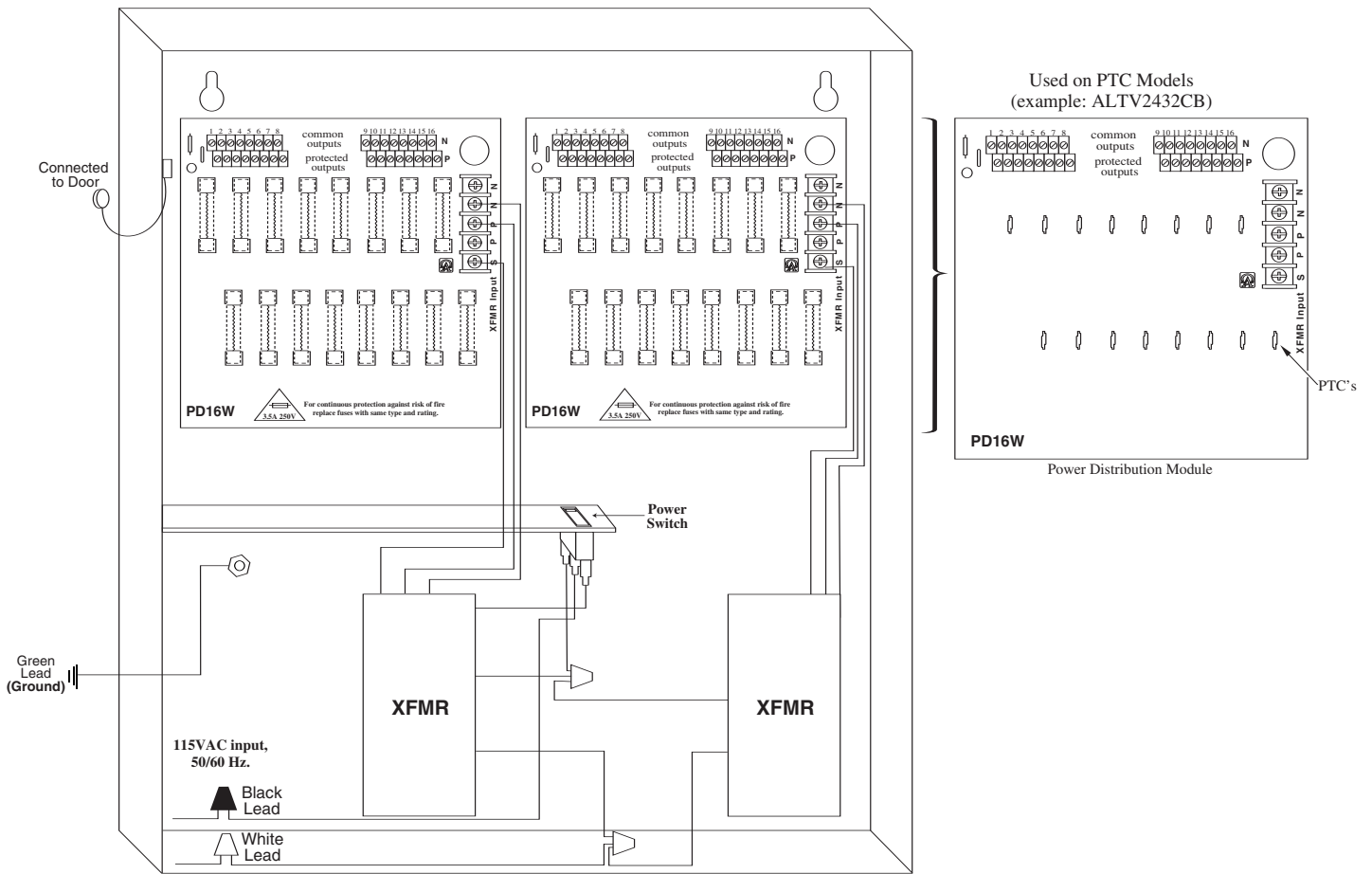

Terminal Blocks for Fig. 1

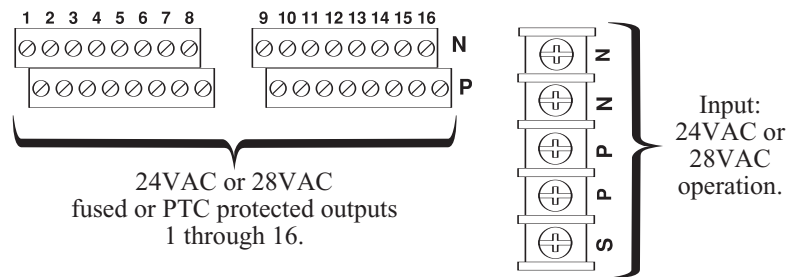
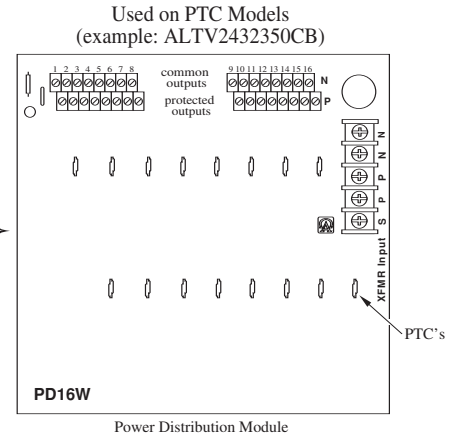
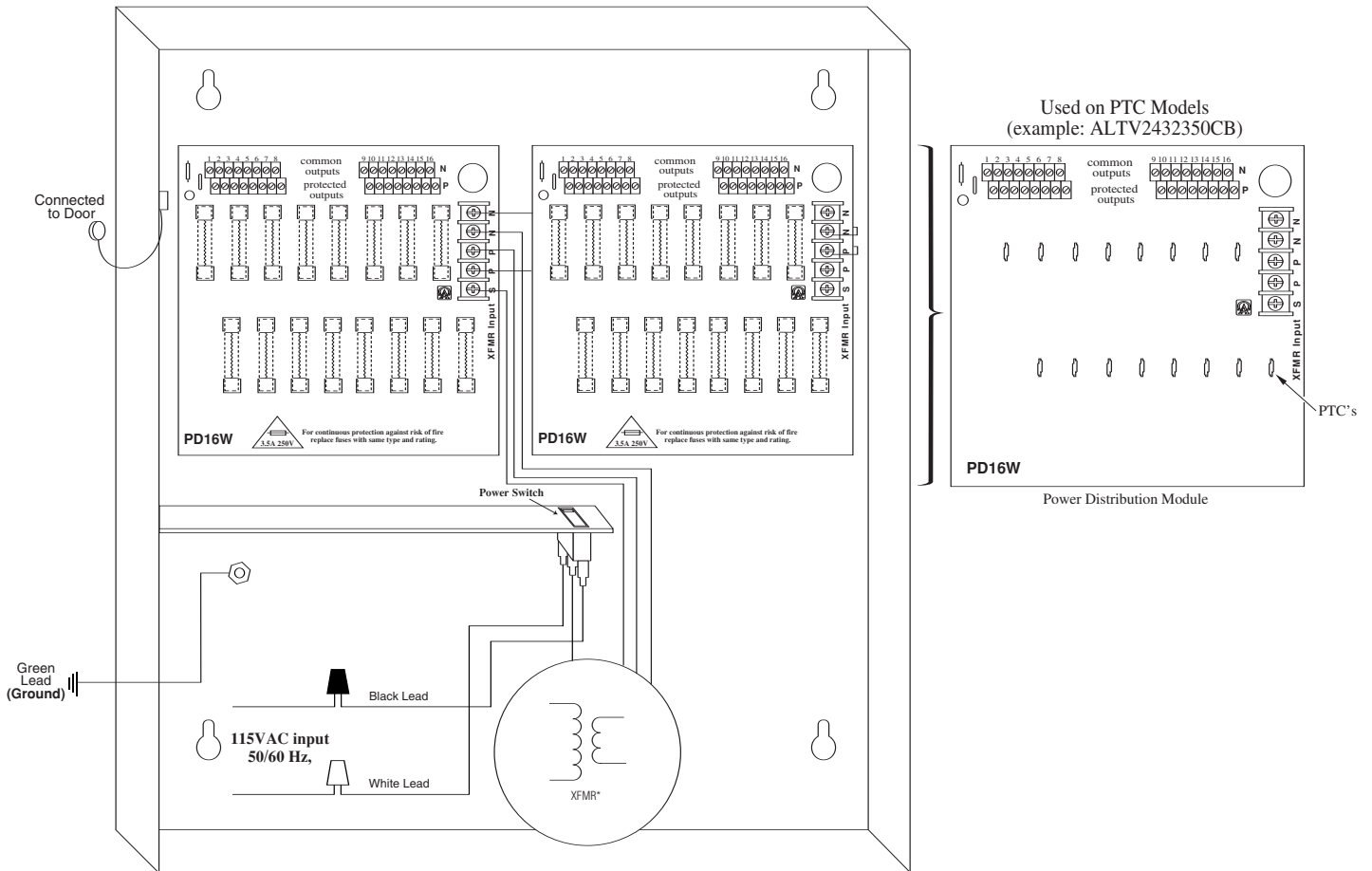

Fig. 2
ALTV2432350 • ALTV2432350CB



Terminal Blocks for Fig. 2

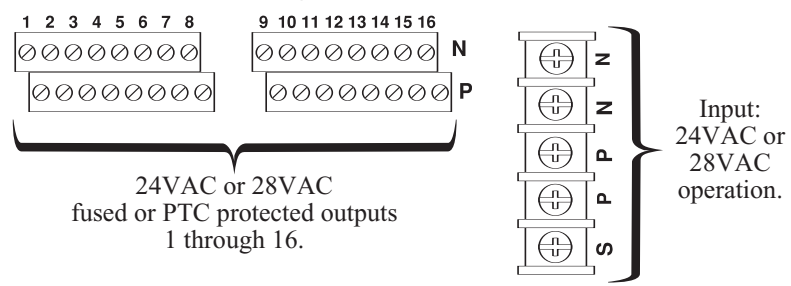
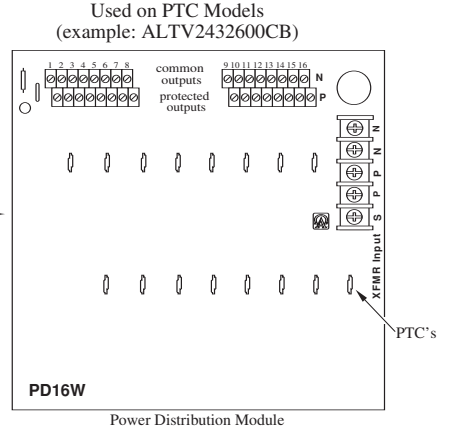
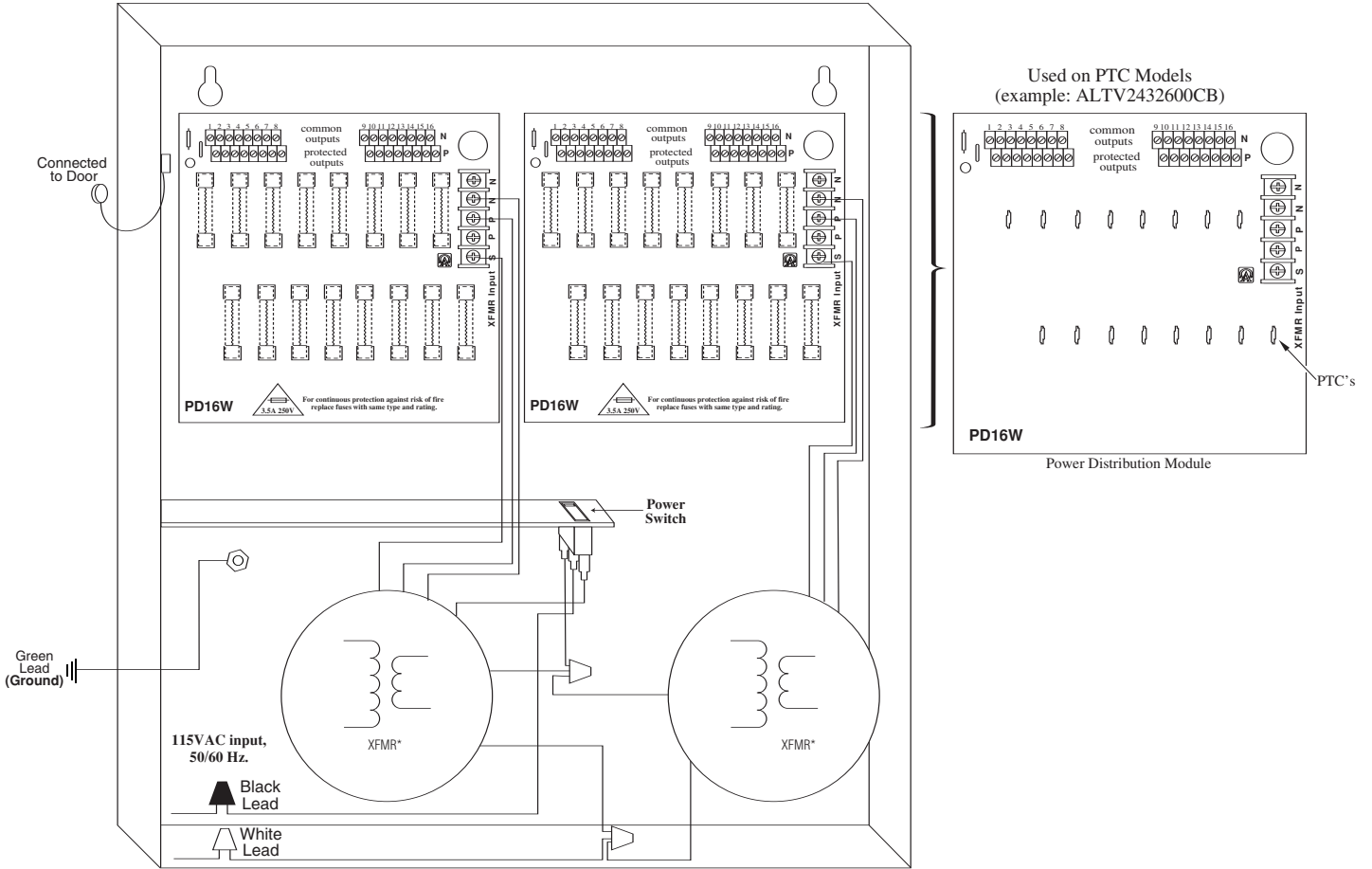
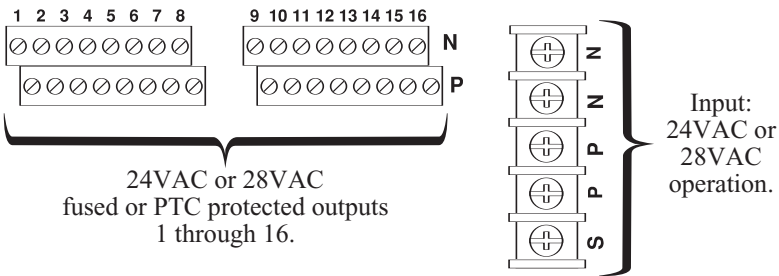

Fig. 3
ALTV2432600 • ALTV2432600CB



Terminal Blocks for Fig. 3



Enclosure Dimensions:

13"H x 13.5"W x 3.5"D

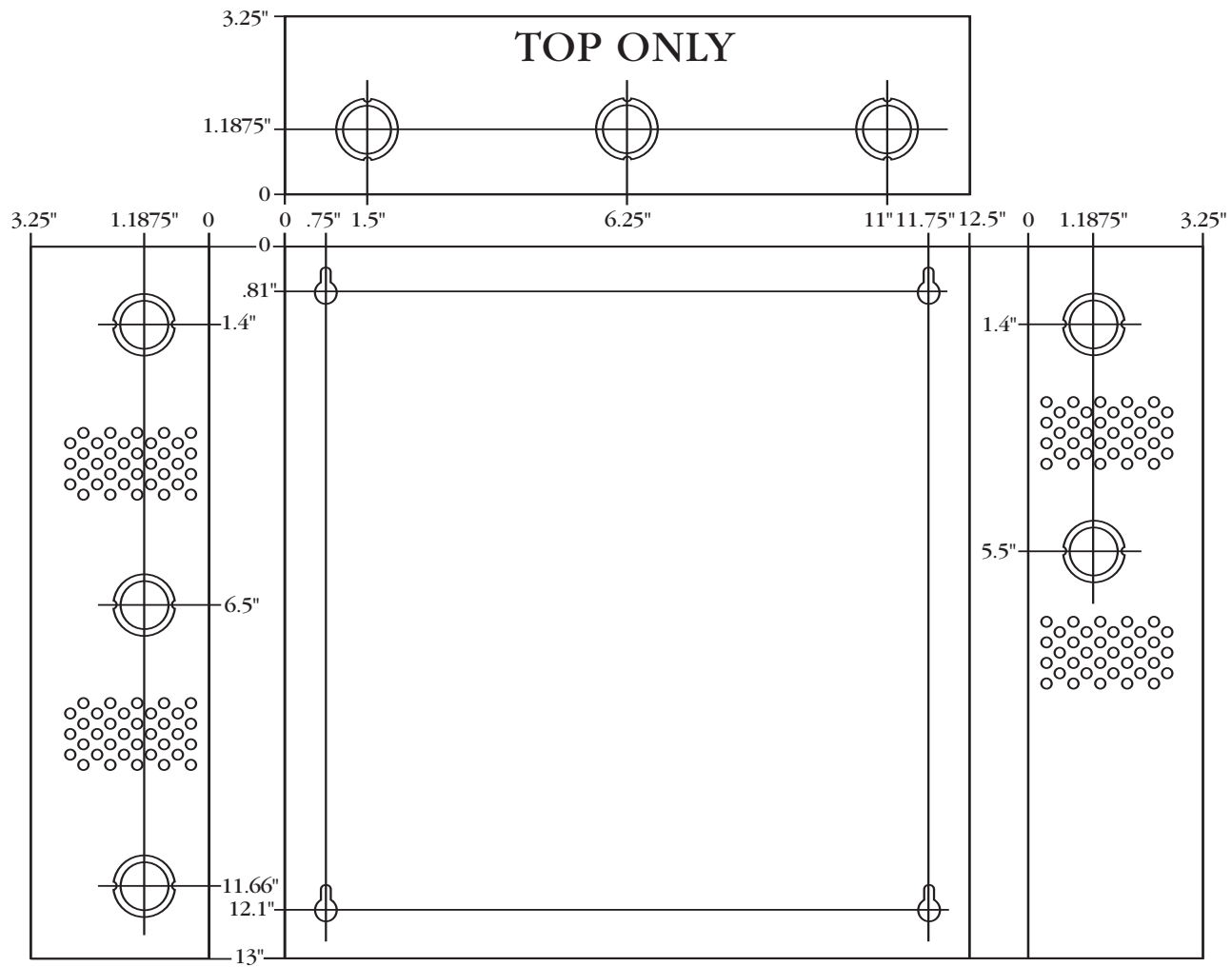

Notes:

Altronix is not responsible for any typographical errors.

Altronix Corp.
140 58th Street, Brooklyn, New York 11220 USA, 718-567-8181, fax: 718-567-9056
web site: www.altronix.com, e-mail: info@altronix.com, Lifetime Warranty, Made in U.S.A.
IIALTV2432Series B09E

