

EPS10-1 AND EPS10-2 Alarm Pressure Switches



Models Available

EPS10-1	One SPDT Switch
EPS10-2	Two SPDT Switches
EPSA10-1	ULC/Canadian Version
EPSA10-2	ULC/Canadian Version

Replacement Parts

S07-66-02	Replacement Cover Screws
WFDW	Replacement Cover Wrench
546-8000	Cover Tamper Switch



Product Overview

Sensitivity adjustment wheel, no tools required

Reinforced diaphragm resists pressure spikes

Two conduit entrances provided

NEMA 4 rated

System Sensor EPS10 Series switches are designed for use in wet, dry, deluge, and pre-action automatic sprinkler systems to indicate a discharge from a sprinkler. The EPS10-1 has a single SPDT switch while the EPS10-2 model contains two SPDT switches.

The EPS10 Series features field adjustable pressure sensitivity to provide an alarm response between 4 and 20 psi. It is factory set to respond at 4 – 8 psi on rising or falling pressure. The pressure adjustment wheel requires no special tools and does not affect switch synchronization on the EPS10-2.

Engineering Specifications EPS10-1 (SPDT), EPS10-2 (2/SPDT)

Model shall be an EPS10-1 or EPS10-2 pressure type waterflow switch as manufactured by System Sensor of St. Charles, IL. They shall be installed on the sprinkler system with connection as shown on the drawings and/or as specified herein. Pressure switches shall be of the bellows-activated type.

Switches shall have a maximum service pressure rating of 250 psi and shall be factory adjusted to operate at a pressure of 4 – 8 psi. There shall be one (1) or two (2) SPDT contacts rated at 10.0 Amp @ 125/250 VAC and 2.5 Amp @ 6/12/24 VDC.

The contractor shall furnish and install, where indicated on the plans, pressure switches according to appropriate NFPA standards. Switches shall be provided with a 1/2" NPT male pressure connection to be connected to the alarm check valve of a "wet" sprinkler system, into the intermediate chamber of a "dry" system, or to a pre-action or deluge valve. They shall be activated by any flow of water equal to or in excess of the discharge from one sprinkler head. Switches shall provide 1 knockout type and 1 open hole for 1/2" conduit fitting attachment and a ground screw provision for electrical grounding.

The switch enclosure shall be weatherproof and carry a UL 4x/NEMA 4 rating when used with proper electrical fittings and conduit. The cover shall incorporate tamper-resistant screws.

The unit shall be listed by Underwriters Laboratories, Inc. and approved by Factory Mutual.



Specifications

Maximum Operating Pressure

250 psi

Differential

Approximately 3 psi throughout range

Maximum Adjustment Pressure Range

4 to 20 psi

Factory Setting

Operates at rising pressure 4 to 8 psi

Pressure Connection

1/2" NPT male glass reinforced nylon

Switch Contact Ratings

EPS10-1: One set SPDT (Form C)
 EPS10-2: Two sets SPDT (Form C)
 10.0 A, 1/2 HP @ 125/250 VAC
 2.5 A @ 6/12/24 VDC

Dimensions

5.12" H x 3.325" W x 4.250" L
 (13.0 cm x 8.4 cm x 10.8 cm)

Operating Temperature Range:

Indoor or outdoor use
 -40°F to 160°F (-40°C to 71°C)

Cover Tamper Switch

UL Models: Optional P/N 546-8000
 ULC Models: Factory Installed

Enclosure

Rated UL 4x, NEMA 4 for indoor or outdoor use

Shipping Weight

1.2 lbs. (.54 Kg)

Service Use

Automatic Sprinkler: NFPA 13
 One or Two Family Dwelling: NFPA 13D
 Residential Occupancies up to 4 Stories: NFPA 13R
 National Fire Alarm Code: NFPA 72

Warranty

3 years

Pressure Switch Basic Dimensions

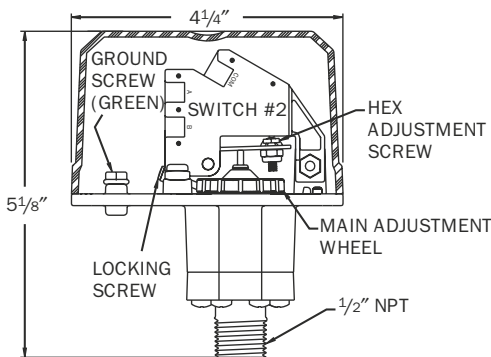

Electrical Connections for EPS10-1 and EPS10-2

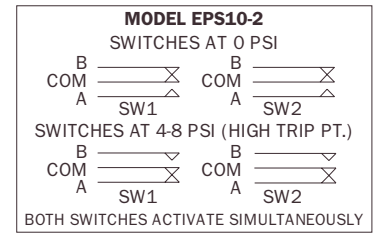
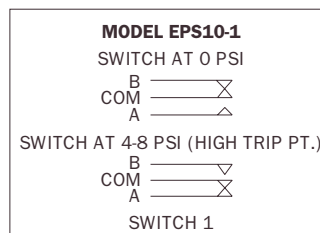

Typical Sprinkler Applications

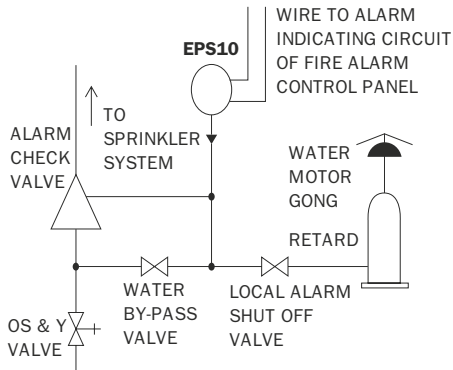

WET SYSTEM

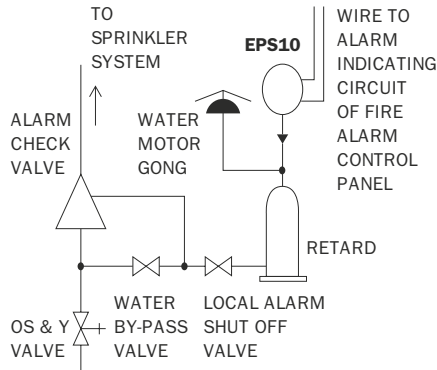

WET SYSTEM

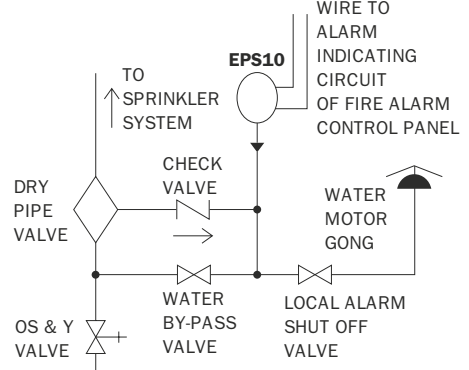

DRY SYSTEM

Ordering Information

Model	Description
EPS10-1	Alarm Waterflow Pressure Switch, One SPDT, 4-20 PSI
EPS10-2	Alarm Waterflow Pressure Switch, Two SPDT, 4-20 PSI
EPSA10-1	ULC/Canadian Version
EPSA10-2	ULC/Canadian Version

Replacement Parts

Model	Description
S07-66-02	Replacement Tamper Screws for Cover of EPS
WFDW	Replacement Tamper Proof Wrench for Cover of EPS
546-8000	Cover Tamper Switch for EPS Series

System Sensor Sales and Service

System Sensor Headquarters

3825 Ohio Avenue
 St. Charles, IL 60174
 Ph: 800/SENSOR2
 Fx: 630/377-6495
 www.systemsensor.com

System Sensor Canada

Ph: 905.812.0767
 Fx: 905.812.0771

System Sensor Europe

Ph: 44.1403.891920
 Fx: 44.1403.891921

System Sensor in China

Ph: 86.29.8832.0119
 Fx: 86.29.8832.5110

System Sensor in Singapore

Ph: 65.6273.2230
 Fx: 65.6273.2610

System Sensor - Far East

Ph: 85.22.191.9003
 Fx: 85.22.736.6580

System Sensor - Australia

Ph: 613.54.281.142
 Fx: 613.54.281.172

System Sensor - India

Ph: 91.124.237.1770 x.2700
 Fx: 91.124.237.3118

System Sensor - Russia

Ph: 70.95.937.7982
 Fx: 70.95.937.7983